

essentia  
audiotools

# User Manual

Rev 2.0 September 2015

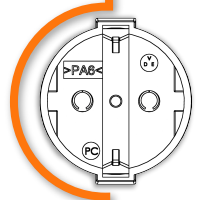
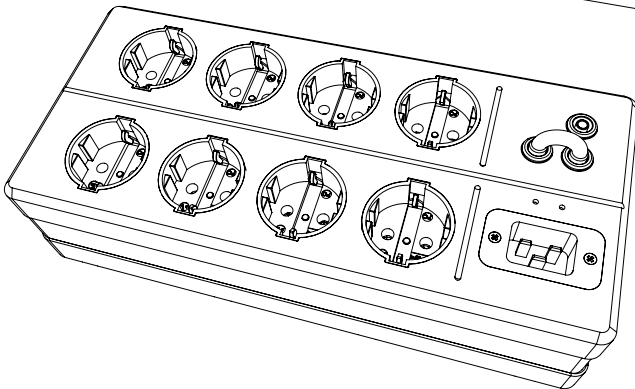
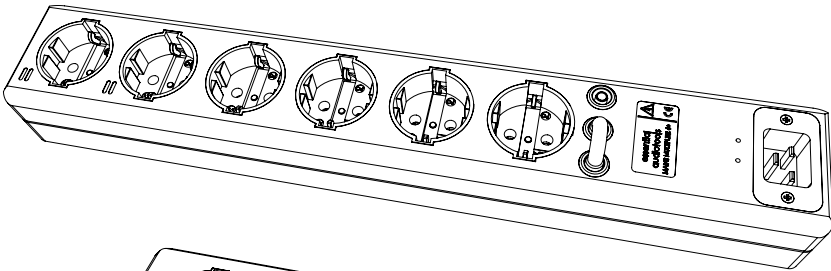

# Contents

---

Introduction	.....	page 3
Description	.....	page 4
Safety precautions	.....	page 5
Connections	.....	page 6
Specifications	.....	page 10
Problem solving	.....	page 11
Warranty	.....	page 11



# Introduction

---

Thank you for purchasing this Essential Audio Tools Mains Multiplier 6+ / Mains Multiplier 8+!

'Essential Audio Tools' is a Square Audio brand name. The name speaks for itself, tools which are very essential for music reproduction. And better reproduction often means more involvement.

Our "Essential Audio Tools" are products to improve the sound of your audio equipment where it all begins: the mains power supply. The power from the mains socket is being "abused" even before it enters your audio equipment. The energy company uses the mains supply to control government property equipment, like streetlights. Also other equipment is communicating with each other by use of the mains power supply. But there is more: the past 25 years switching power supplies have made their way into computers, TV's and other home appliances. These devices pollute the mains supply with nasty pulses. This "Trojan Horse" comes into your equipment without knowing it. The pollution has to be taken out of the mains power supply before it reaches your (analogue) audio equipment. The Essential Audio Tool's cables, distribution boxes, filters and phase indicator make any audio set perform better.

Essential Audio Tools is investing lots of time and effort to make this product as good as it can be. They are all made with use of precision CNC machining. Beautifully shaped, well-designed and manufactured from top-quality material by experts. Have a look at our quality and listen to the results, then you know what we mean.

We wish you lots of pleasure!

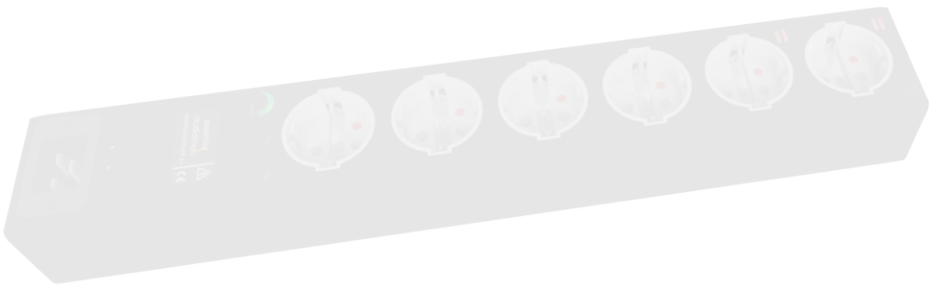

# Description

---

The Mains Multiplier is not a regular multiple socket but more a work of art made on a CNC machine that shapes this form out of one piece synthetic material. Yes... synthetic! The results speak for them selves, optical as well as electrical.

The type of outputs is chosen because of the high contact pressure, which is obvious when putting in or pulling out an electric plug. More contact pressure and an optimal contact surface do create a low resistance value. This is very important for a good power distribution.

The wiring for phase, neutral and earth is connected by a star principle. Every output has its own wiring towards the feed cable. Peaks in the current or interference signals that appear on the earth contacts of one socket will now have less effect on the other sockets.

Just behind the IEC input connector a Pulse Protector is integrated. This prevents peaks and pulses to reach your equipment. Our Pulse Protector is also available as a separate unit, please check our website.

## Where to use

Wherever you need to connect multiple loads to the mains, the Mains Multiplier is the best choice. Of course you will have to use high performance power cords, else the Mains Multiplier will not perform at its best. It's a combination of factors, only if you use the Mains Multiplier in combination with high performance power cords

- like our Current Conductor - you will have the maximum results for your audio system.

Of course it is possible to use the Mains Multiplier as an ordinary multiple socket without high performance supply cables. Our advice is to buy better power cords, the results will be rewarding.

## What to expect

An improvement in dynamics, a much better sound image and a lower hum level. The sound character of your audio system remains, fortunately!

By using the Mains Multiplier with integrated Pulse Protector your equipment has less trouble with electrical failures induced by distortion on your network, and it is better protected against damage through lightning impacts nearby. A guarantee that lightning impacts will not damage your devices can not be given because the energy-content of lightning is too high.

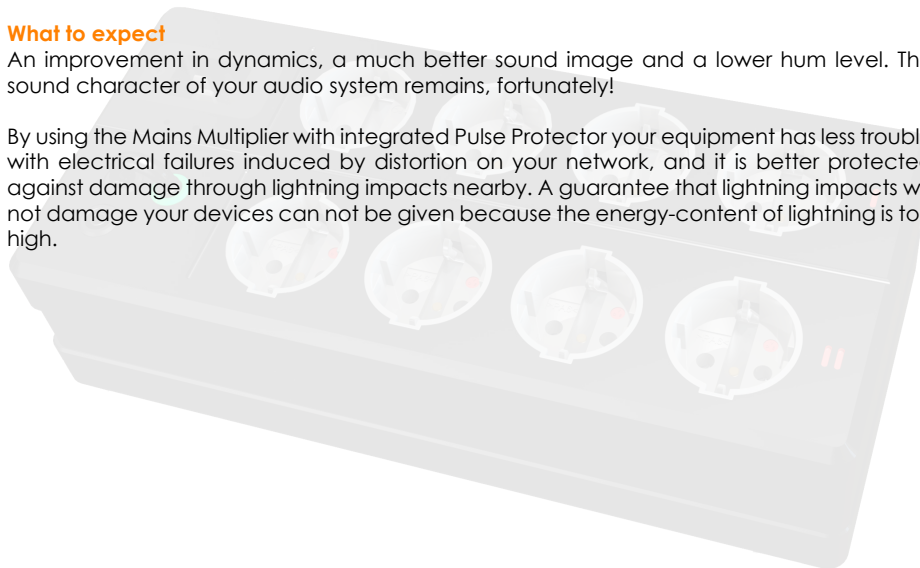

# Safety precautions

For your protection and safe operation of the unit, please read the following:

## Avoid water and other liquids

To avoid risk of fire and electrical shock: do not expose this device to moisture. Use indoors and in dry locations only. Do not expose to dripping and/or splashing. Do not place objects filled with liquids, such as vases, on or near the device. Do not operate the unit if any liquid is spilled on or into the unit; return it to your dealer for servicing.

## Don't open the device

To avoid risk of electrical shock: do not open the device. There are no user serviceable parts inside. Repairs are to be performed by qualified personnel only.

## Unplug before cleaning

Always unplug the unit before cleaning. It is only necessary to clean the unit with a clean, dry cloth or duster. Do not use any cleaning solutions, sprays, or water.

## Connect to mains ground

For safety reasons and to protect connected equipment, this product **MUST** be connected to mains with a three conductor power cord which includes a working ground conductor. The power cord **MUST** be plugged into a grounded AC power outlet (3-pin). Do not use a 3-to-2-pin adapter to defeat the grounding pin. Failure to plug this product into a grounded outlet through a ground conductor including mains cord may result in personal injury or damage to your equipment. Call a licensed electrician if you are unsure if your AC outlets are properly grounded.

## Do not overload individual outputs

Do not connect loads which draw more current than the maximum rating for each individual outlet. Possible damages due to exceeding these maximum ratings will void warranty. The **MAXIMUM CURRENT** rating for each outlet may differ, please look at the **Specifications** for maximum loads.

## Do not exceed maximum total load

The total current drawn from all outlets together may not exceed 16 Amps. At 230 Volts mains this is equivalent to 3680W.

## Check your supply voltage

This device is designed for 220-240 V ~ AC, 50/60 Hz mains supply. Connecting to a different voltage may damage the device and warranty will be void.

## Avoid condensation

If the device is moved from a cold to a warmer area, allow warming up to ambient temperature for at least 1 hour without connection to the mains supply. This to avoid condensation inside the device.

## Connect power cords safely

Power supply cords should be routed in such a way that they are not likely to be walked on or pinched by items upon or against them, paying particular attention to cords at plugs, convenience receptacles, and the point where they exit from the appliance. Do not route power cords near heat sources.

# Connections

Integrating your new Mains Multiplier is as easy as can be.

Just connect the Mains Multiplier to your wall socket. Don't bother about the phase of the wall socket, you don't have to check it. The Mains Multiplier 6+ (figure 1) and the Mains Multiplier 8+ (figure 2) do have a phase indicator inside which gives the following indications:

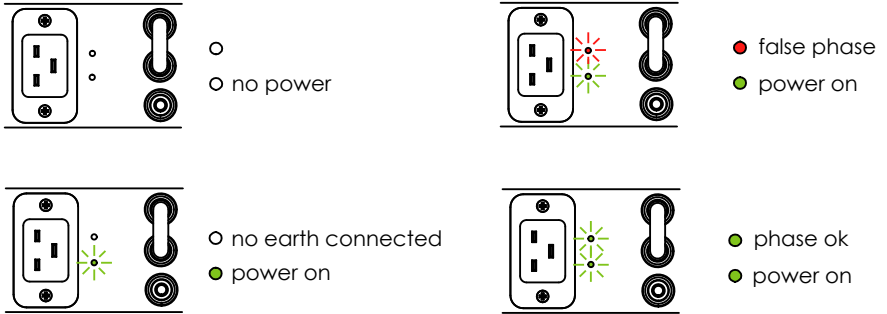

Figure 1. Phase indication Mains Multiplier 6+

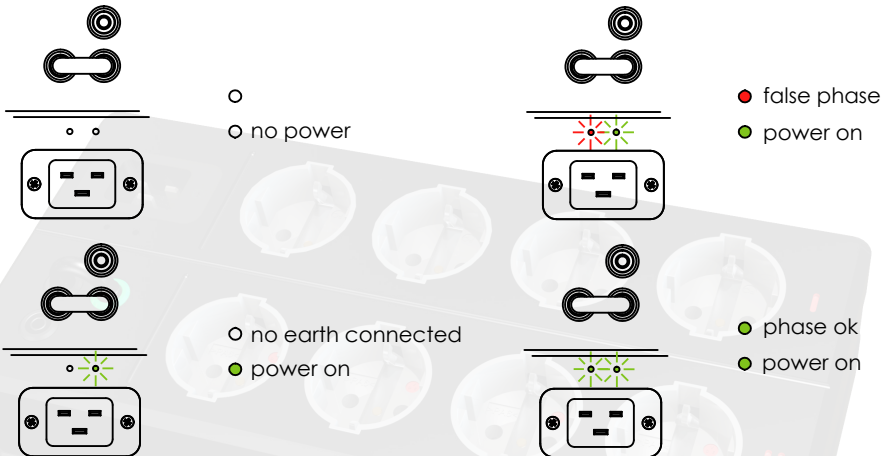

Figure 2. Phase indication Mains Multiplier 8+

If you get a false phase indication by a red light, you should reverse the power cable plug in the wall socket. You will see that both indicators will light green which means that power is on and phase is ok.

For countries with an earth pin in the middle of the wall socket (France, Belgium) it is not possible to reverse the power cord plug in the wall socket. You should ask a technician to reverse the neutral and phase in your wall socket, NOT in your power cord. Don't do this yourself, the mains voltage is dangerous!

### Connecting the Mains Multiplier 6+

The Mains Multiplier 6+ has two outputs with each a Common Mode filter and four direct outputs, see figure 3. The direct outputs all have a 10 Amps maximum current each, the filtered outputs have a 6 Amps maximum current each. The **total current of all six outputs may not exceed 16 Amps**.

You can NOT just connect loads to any group, **so read this carefully!**

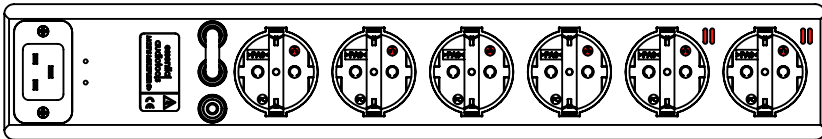

Figure 3. Mains Multiplier 6+

- Group I** has four outputs, they are wired directly to the mains. You can connect heavy loads to this group, like power amplifiers and heavy subwoofers.
- Group II** has two outputs, each of them have a separate Common Mode filter. This group is meant to feed pre-amplifiers, digital surround processors light to medium subwoofers. Integrated amplifiers can go on this group as well, but please check power carefully.

The maximum currents or power you can draw from each group is different:

<b>Group I</b>	4 outputs	maximum 10A each	maximum 16A in total
<b>Group II</b>	2 outputs	maximum 6A each	maximum 16A in total

To prevent that you do exceed maximum load, use the power indication (W or Watt) at the back of your equipment to calculate the total power for each group. The value of the fuse in your equipment is not important for the calculation.

After checking the power use the following numbers:

<b>Group I</b>	4 outputs	maximum 2300W each	maximum 3680W in total
<b>Group II</b>	2 outputs	maximum 1380W each	maximum 2760W in total

Total maximum power connected to the Mains Multiplier 6+ is 3680W.

### Connecting the Mains Multiplier 8+

The Mains Multiplier 8+ has four outputs with each a Common Mode filter and four direct outputs, see figure 4. The direct outputs all have a 10 Amps maximum current each, the filtered outputs have a 6 Amps maximum current each. The **total current of all eight outputs may not exceed 16 Amps**.

You can NOT just connect loads to any group, **so read this carefully!**

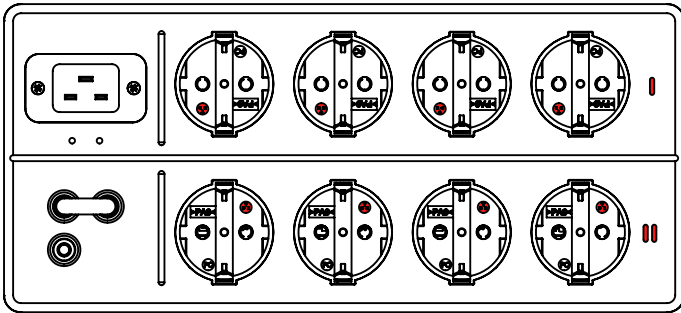

Figure 4. Mains Multiplier 8+

- Group I** has four outputs, they are wired directly to the mains. You can connect heavy loads to this group, like power amplifiers and heavy subwoofers.
- Group II** has four outputs, each of them have a separate Common Mode filter. This group is meant to feed pre-amplifiers, digital surround processors light to medium subwoofers. Integrated amplifiers can go on this group as well, but please check power carefully.

The maximum currents or power you can draw from each group is different:

<b>Group I</b>	4 outputs	maximum 10A each	maximum 16A in total
<b>Group II</b>	4 outputs	maximum 6A each	maximum 16A in total

To prevent that you do exceed maximum load, use the power indication (W or Watt) at the back of your equipment to calculate the total power for each group. The value of the fuse in your equipment is not important for the calculation.

After checking the power use the following numbers:

<b>Group I</b>	4 outputs	maximum 2300W each	maximum 3680W in total
<b>Group II</b>	4 outputs	maximum 1380W each	maximum 3680W in total

Total maximum power connected to the Mains Multiplier 8+ is 3680W.



## Connecting Earth

Your Mains Multiplier must be connected to an earthed wall socket, however if you do not have earth the Mains Multiplier will still function. Even without an earthed wall socket the Mains Multiplier itself will make a connection between all earth contacts of your equipment. This will prevent that small currents will run through your interlinks due to differences between earth potentials at your equipment's chassis. So even without an earthed wall socket you should keep using your earthed power cords.

On both the Mains Multiplier 6+ and Mains Multiplier 8+ you will find a tool which is unique for Essential Audio Tools. It is called the **Ground Bridge**.

It consists of three terminals (one green, two black) which can be connected in two ways by a bridge. With the Ground Bridge you are able to choose between the earth terminal in your wall socket or an external earth you supply yourself. This external earth can be an earth pole which you can have installed by a specialized company. The earth pole (outside your house, deep in the ground) should have an exclusive connection to the position where the Mains Multiplier 6+ or Mains Multiplier 8+ is. Nothing else should be connected to this special earth pole. The Mains Multiplier's green socket must be used to connect your external earth.

### Do not plug or unplug the Ground Bridge when the Mains Multiplier is powered!

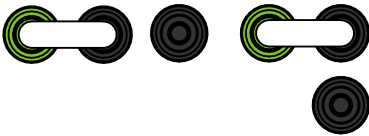

Figure 5. Wall socket earth applied



Figure 6. External earth applied

In figure 5 you can see how the Ground Bridge is connecting the earth pin of the wall socket with the earth connection inside the Mains Multiplier 6+ or Mains Multiplier 8+.

In figure 6 you can see how the Ground Bridge is placed so the green socket can be used for the external earth.

Please check the indicators, you should have two green lights. One green light means your earth connection is not proper.

## Tips

For maximum noise reduction, it is best to keep all power and audio cables in your setup separated by some distance from each other and to avoid routing cables in parallel.

Use high-quality power cords (our Current Conductor for example) to connect your equipment. The screening will prevent stray-fields to reach your audio cables. Order your power cords as short as possible, for best results.

Do not connect distribution blocks or mains splitters to the outputs. It will possibly cause interference.

Feed ALL your equipment from the Mains Multiplier. Having an extra external power feed to one of your pieces of equipment will possibly cause interference and/or hum.

# Specifications

---

Rated voltage 220-240 V ~ AC

50/60 Hz

## Protecting Phase-Neutral, Phase-Earth and Neutral-Earth

Maximum voltage	250 V ~ AC
Maximum peak-voltage	2500 V
Maximum peak-current	4500 A
Maximum peak-energy	3 x 65 Joule
Response time	< 25 nanoseconds

## Mains Multiplier 6+

Maximum continuous current per <b>filtered</b> socket	6 Amps
Maximum continuous current per <b>unfiltered</b> socket	10 Amps
Maximum continuous total current all sockets together	16 Amps
Maximum continuous total power all sockets together	3680W

Size	424(l) x 70(w) x 71,5(h) in mm
Weight	1,4 kg

## Mains Multiplier 8+

Maximum continuous current per <b>filtered</b> socket	6 Amps
Maximum continuous current per <b>unfiltered</b> socket	10 Amps
Maximum continuous total current all sockets together	16 Amps
Maximum continuous total power all sockets together	3680W

Size	298(l) x 135(w) x 96,5(h) in mm
Weight	3,2 kg



There are no serviceable parts inside. Do not open your Mains Multiplier!

Please check the following before requesting service:

- 1 – Check the wall socket by plugging in a light or load to check power is there.
- 2 – Check if the power cord from the wall socket to the Mains Multiplier is functioning and make sure the power cord is plugged deep enough into the Mains Multiplier's input.
- 3 – Check your equipment and the power cord used directly into a wall socket to test if they work directly on the wall socket.

If all of the above is tested and working and the unit is still not functioning, then contact your local dealer for service.

## Warranty

---

Essential Audio Tools products have a warranty period of two years from date of purchase. This warranty covers manufacturing defects and failures within product's specifications.

When warranty is claimed the original bill with the buyer's name and date of purchase should be presented.

Warranty will void if:

- The device has not been used in conformance with the user manual.
- The device is used in an industrial environment.
- The bill has been altered or made illegible.
- Modifications or repairs have been performed by non-authorized persons.
- Malfunction is caused by device-external conditions, like among other things: overloading, atmospheric discharges and fire or water damages.

Warranty is limited to internal damages regarding the Mains Multiplier itself: all eventual consequential damages are not covered by warranty.

# essential audiotools

MORE INFORMATION:  
[WWW.ESSENTIALAUDIOTOOLS.COM](http://WWW.ESSENTIALAUDIOTOOLS.COM)

